



Rural CAP

Rural Alaska Community Action Program, Inc.

731 E. 8th Avenue
Anchorage, AK 99501
907.279.2511
www.ruralcap.org

IFB WX 2024-003 Addendum 1

GENERAL BUILDING MATERIALS

12/12/2024

Closes: 12/30/2024 at 4:30 PM

Appendix F update. A misprint was found on Appendix F; it currently reads Windows Specifications, and should be Material Specification. Please use the attached corrected Appendix F as reference, all other parts of this IFB remain the same.

APPENDIX F

LISTING OF MATERIALS/SERVICES REQUIRED

The Rural Alaska Community Action Program, Inc. (RurAL CAP) invites you to participate, through the competitive bid process, in the supply for the listed items for the benefit of the Alaskan communities listed in Attachment III, in the estimated quantities shown. The material quantities included in this bid are estimates for approximately 10 homes FY2025 for the village of Koyuk.

MATERIALS SPECIFICATIONS (See Attachment II)

QUANTITY, DESCRIPTION LISTING (See Attachment III)

EMAIL bids to Darrel Behymer at dbehymmer@ruralcap.org and Mike McAlpin at mmcalpin@ruralcap.org

PLEASE SPECIFY BID NUMBER AND TITLE ON THE EMAIL SUBJECT LINE ALONG WITH BIDDER'S NAME.

Bid must include:

1. Appendix G (complete all of the OFFER section, including signature of authorized official)
2. Attachment III, including unit cost and extended cost for all items and freight to FOB.
3. List of References
4. Provide any and all information required in Attachment II, Specifications. Provide information showing materials meet specifications, or at a minimum, a statement that all materials to be supplied will conform to Attachment II, Specifications.

BIDS MUST BE RECEIVED NO LATER THAN 4:30 PM 12/30/2024

Proposal Question

All questions pertaining to this solicitation must be submitted in writing by 12/23/2024. Questions may be emailed to Mike McAlpin mmcalpin@ruralcap.org.

Answers/Amendments to the bid packet will be emailed to all firms who have received the proposal and have provided an email address or to RurAL CAP. To register your email at dbehymmer@ruralcap.org



IFB WX2024-003

GENERAL BUILDING MATERIALS

Closes: 12/30/2024 at 4:30 PM

This Invitation for Bid consists of the following listed documents which will form the "Contract Document" and which shall represent the complete understanding of the parties with respect to the matters involved therein and which may not be changed except by a written document signed by RurAL CAP and the contractor involved.

Funding is provided by the U.S. Department of Energy (DOE), U.S. Department of Health and Social Services (HSS) and the Alaska Housing Finance Corporation (AHFC).

All questions pertaining to this IFB must be submitted via email by 12/23/2024 to Mike McAlpin at mmcalpin@ruralcap.org.

		<u>Page #</u>
APPENDIX A.	Definitions	1
APPENDIX B.	Instruction to Bidders	2-4
APPENDIX C.	General Terms and Conditions.....	5-17
APPENDIX D.	Compliance and Certifications.....	18-23
APPENDIX E.	Standard Procedures	24
APPENDIX F.	Listing of Materials/Services	25
	Required to be provided	
APPENDIX G.	Solicitation, Offer and Award	26
APPENDIX H.	Additional Provisions	27
ATTACHMENT I	Bid Evaluation/ Worksheet	28-29
ATTACHMENT II	Material Specifications	30-35
ATTACHMENT III	Material Lists (By Community)	

APPENDIX A

DEFINITIONS

1. Definitions

As used herein:

- (a) "Parent company" is a company which either owns at least a majority (more than 50%) of a company or controls the activities and basic business policies of the company.
- (b) The term "subcontractor" means any contract for services or supplies including purchase orders entered into by the contractor.
- (c) The term "contractor" means the successful bidder who is awarded part or all of the contracts under these bids.
- (d) The term "solicitation" or "Invitation for Bids" (IFB) means the document soliciting bids through the formal advertising method of procurements.
- (e) The term "bid" or "offer" means an offer to perform the work described at a fixed unit price.
- (f) The term "bidder" or "offerer" means an individual or company submitting a response to the IFB.
- (g) "Contracting Agency" is Rural Alaska Community Action Program, Inc. (RurAL CAP).
- (h) "Contract Officer" is Rural Alaska Community Action Program, Inc. (RurAL CAP) - Executive Director.

APPENDIX B

INSTRUCTION TO BIDDERS

2. PREPARATION OF OFFERS:

- (a) Offerers are expected to examine the drawings, specifications, and other pertinent aspects of all instructions. Failure to do so will be at the offerers risk.
- (b) Each offerer shall furnish the information required by the solicitation.
- (c) The offerer shall sign the solicitation and print or type its name on the schedule and each Continuation Sheet thereof on which an entry is made. Bids signed by an agency are to be accompanied by evidence of agency signature authority unless such evidence has been previously furnished.
- (d) Unit price for each unit offered shall be shown and such price shall include packing unless Otherwise specified. Bids must contain firm, fixed per unit price. The contract awarded shall be a firm, fixed price contract.
- (e) A total shall be entered in the Amount Column of the schedule for each item offered. In case of discrepancy between a unit price and extended price, the unit price will be presumed to be correct, subject, however, to correction to the same extent and in the same manner as any other mistake.
- (f) Offers for supplies or services other than those specified will not be considered unless authorized by the solicitation.
- (g) Offerer must state a definite time for delivery of supplies or for performance of services unless otherwise specified in the solicitation.
- (h) Time, if stated as a number of days, will include Saturdays, Sundays and holidays unless otherwise specified in the solicitation.
- (i) Each bidder shall indicate the name and address, including street address and zip code, and complete telephone number including area code, of the particular supply house and/or point from which the supplies will be furnished and/or shipped.
- U) Bidders must include proof of performance by submitting a minimum of three references, including Company, Contact Person and Phone Number.
- (k) Although bidders are left to their own discretion as to the determination of freight methods and costs, they are required to apply the most cost-effective, yet expedient methods available. Expected freight contractor company name must be included in the return bid.
- (l) Quantities ordered may vary according to per item cost and current budget constraints.

3. EXPLANATION TO OFFERERS:

Any explanation desired by an offerer regarding the meaning or interpretation of the solicitation, drawings, specifications, etc., must be requested in writing and with sufficient time allowed for a reply to reach offerers before the submission of their offers. Oral explanations or instructions given before the award of the contract will not be binding. Any verbal information given to a prospective offerer concerning a solicitation will be furnished in writing to all prospective offerers as an amendment of the solicitation, if such information is necessary to offerers in submitting bids on the solicitation or if the lack of such information would be prejudicial to uninformed offerers.

4. ACKNOWLEDGEMENT OF AMENDMENTS TO SOLICITATIONS:

Receipt of an amendment to a solicitation by an offerer must be acknowledged (a) by signing and returning the amendment, or (b) by letter or telegram. Such acknowledgement must be received prior to the hour and date specified for receipt of offers.

5. SUBMISSION OF OFFERS:

- (a) Offers and modifications thereof shall be enclosed in sealed envelopes and addressed as specified in the solicitation. The offerer shall show the hour and date specified in the solicitation for receipt, the solicitation number, and the name and address of the offerer on the face of the envelope.
- (b) FAX offers will not be considered unless authorized by the solicitation; however, offers may be modified by FAX notice, provided such notice is received prior to the hour and date specified for receipt.
- (c) Samples of items, when required, must be submitted within the time specified and unless otherwise specified by RurAL CAP, at no expense to RurAL CAP. If not destroyed by testing, samples will be returned at offerer's request and expense, unless otherwise specified by the solicitation.
- (d) No bidder may submit a bid unless such bid is complete as to all materials listed in the IFS. All items listed must be bid unless otherwise specified by RurAL CAP.
- (e) The offerer shall insert in the applicable space on the offer form either its own Employer's Identification Number or that of the parent company, if there is one.

6. MODIFICATION OR WITHDRAWAL OF OFFERS:

- (a) If this solicitation is advertised, offers may be modified or withdrawn by written or FAX notice received prior to the exact hour and date specified for receipt of offers. An offer also may be withdrawn in person by an offerer or its authorized representative, provided the identity is made known and a receipt issued for the offer, but only if the WITHDRAWAL is made prior to the exact hour and date set for receipt of offers.
- (b) If this solicitation is negotiated, offers may be modified (subject to paragraph 8, when applicable) or withdrawn by written or telegraphic notice received at any time prior to award. Offers may be withdrawn in person by an offerer or its authorized representative, provided the identity is made known and a receipt be signed for the offer prior to award.

7. LATE BIDS, MODIFICATIONS OF BIDS, OR WITHDRAWAL OF BIDS:

- (a) Any bid received at the office designated in the solicitation after the exact time specified for receipt will not be considered unless it is received before award is made and either:
 - (1) It was sent by email and it is determined by RurAL CAP that the late receipt was due solely to the mishandling by RurAL CAP after receipt at RurAL CAP installation.
- (b) Any modification or withdrawal of a bid is subject to the same conditions as (a), above.
- (c) The only acceptable evidence to establish:
 - (1) The time of receipt at the RurAL CAP email is the electronic time and date stamp.
- (d) Notwithstanding (a) and (b) of this provision, a late modification of an otherwise successful bid which makes its terms more favorable to RurAL CAP will be considered at any time it is received and may be accepted.

8. FAILURE TO SUBMIT OFFER:

If no offer is to be submitted, do not return the solicitation unless otherwise specified. A letter or postcard should be sent to the issuing office advising whether future solicitations for the type of supplies or services covered by this solicitation are desired. Failure of the recipient to offer, or to notify the issuing office that future solicitations are desired, may result in removal of the name of such recipient from the mailing list for the type of supplies covered by the solicitation.

9. DISCOUNTS:

No discounts are to be included in the bids.

10. RURAL CAP - FURNISHED PROPERTY:

No material labor, or facilities will be furnished by RurAL CAP unless otherwise provided for in the solicitation.

11. AWARD OF CONTRACT:

- (a) All bids will be evaluated based on materials that conform to the material specifications, and the cost of the materials F.O.B. designated location or Anchorage International Airport.
- (b) RurAL CAP's basis for awarding this contract will be for the cost for the material package and the contractor's ability to perform successfully under the stated terms and conditions.
- (c) RurAL CAP reserves the right to reject for any reason any or all offers or any part of any offer and to waive informalities and minor irregularities in offers received.
- (d) RurAL CAP expects, but does not guarantee, to purchase the quantities estimated. All materials listed reflect home assessments for the anticipated village projects. It is anticipated that purchases will include the quantities listed, but variations will probably occur. Material purchases are subject to change due to funding reductions or increases, freight and transportation requirements.
- (e) RurAL CAP may accept any item or group of items of any offer, unless the offerer qualifies the offer by specific limitations. Unless otherwise provided in the schedule, offers may be submitted for any quantities less than those specified and Rural CAP reserves the right to make an award of any item for a quantity less than the quantity offered at the unit prices offered unless the offerer specifies otherwise in the offer.
- (f) Bids that are made on materials that do not meet the material specifications referred to above will be considered non-responsive.
- (g) A written award (or Acceptance of Offer) mailed (or otherwise furnished) to the successful offerer within the time for acceptance specified in the offer shall be deemed to result in a binding contract without further action by either party.

APPENDIX C

GENERAL TERMS AND CONDITIONS

12. CHANGES:

RurAL CAP may at any time, by a written order, and without notice to the sureties, make changes, within the general scope of this contract, in any one or more of the following: (i) Drawings, designs, or specifications, where the supplies to be furnished are to be specially manufactured for RurAL CAP; (ii) method of shipment or packing; and (iii) place of delivery. If any such change causes an increase or decrease in the cost of, or the time required for, the performance of any part of the work under this contract, whether changed or not changed by any such order, an equitable adjustment shall be made in the contract price or delivery schedule, or both, and the contract shall be modified in writing accordingly. Any claim by the Contractor for adjustment under this clause must be asserted within 30 days from the date of receipt by the Contractor of the notification of change. If RurAL CAP decides that the facts justify such action, then they may receive and act upon any such claim asserted at any time prior to final payment under this contract. Where the cost of property made obsolete or excess as a result of a change is included in the Contractor's claim for adjustment, RurAL CAP shall have the right to prescribe the manner of disposition of such property. Failure to agree to any adjustments shall be a dispute concerning a question of fact within the meaning of the clause of this contract entitled "Disputes." However, nothing in this clause shall excuse the Contractor from proceeding with the contract as changed.

13. SELLER'S INVOICES:

Invoices shall be marked "Original" and shall contain the following information:

Contract and other number (if any), item numbers, description of supplies or services, sizes, quantities, unit prices, and extended totals. Bill of lading number and weight of shipment will be shown for shipments made on RurAL CAP bills of lading.

14. PAYMENTS:

- (a) The Contractor shall be paid, upon the submission of proper invoices or vouchers, the prices stipulated herein for supplies delivered and accepted or services rendered and accepted, less deductions, if any, as herein provided.
- (b) Unless otherwise specified, payment will be made on partial deliveries accepted by RurAL CAP when the amount due on such deliveries so warrants, or, when requested by the Contractor, payment for accepted partial deliveries shall be made whenever such payment would equal or exceed either \$1,000 or 50 percent of the total amount of this contract.
- (c) RurAL CAP will make an advance payment to the contractor of an amount not to exceed Twenty percent (20%) of the contract price upon notice of shipment of the materials and receipt of invoice. The balance due shall be paid within thirty (30) days after delivery of materials and receipt of invoice and after verification thereof as to quantity, and against the contractor's invoices, notwithstanding any provision of the Contract Documents to the contrary.
- (d) Payment by RurAL CAP to contractors shall not constitute acknowledgement by RurAL CAP that the materials paid for conform to the specifications.
- (e) Materials shall be delivered to a designated ramp, Anchorage International Airport, according to delivery schedule, unless otherwise specified.

15. EXTRAS:

Except as otherwise provided in this contract, no payment for extras shall be made unless such extras and the price therefore have been authorized in writing by RurAL CAP.

16. VARIATION IN QUANTITY:

No variation in the quantity of any item called for by this contract will be accepted unless such variation has been caused by conditions of loading, shipping, or packing, or allowances in manufacturing processes, and then only to the extent, if any, specified elsewhere in this contract.

17. RESPONSIBILITY FOR SUPPLIES:

Except as otherwise provided in this contract, (i) the Contractor shall be responsible for the supplies covered by this contract until they are delivered at the designated delivery point, regardless of the point of inspection; (ii) after delivery to RurAL CAP at the designated point and prior to acceptance by RurAL CAP or rejection and giving notice thereof by RurAL CAP, RurAL CAP shall be responsible for the loss or destruction of/or damage to the supplies only if such loss, destruction, or damage results from the negligence of officers, agents, or employees of RurAL CAP acting within the scope of their employment; and (iii) the Contractor shall bear all risks as to rejected supplies after notice of rejection, except that RurAL CAP shall be responsible for the loss, or destruction of, or damage to the supplies only if such loss, destruction or damage results from the gross negligence of officers, agents, or employees of RurAL CAP acting within the scope of their employment.

18. INSPECTION:

- (a) All supplies (which term throughout this clause, includes without limitation raw materials, components, intermediate assemblies, and end products) shall be subject to inspection and test by RurAL CAP, to the extent practicable at all times and places including the period of manufacture, and in any event prior to acceptance. RurAL CAP reserves the right to inspect all materials at point of origin prior to loading. Such inspection does not constitute an inventory, and RurAL CAP assumes no liability for loss, damage, or shortage of materials as a result of any initial inspection.
- (b) In case any supplies or lots of supplies are defective in materials or workmanship or otherwise not in conformity with the requirements of this contract, RurAL CAP shall have the right either to reject them (with or without instructions as to their disposition) or to require their correction. Supplies or lots of supplies which have been rejected or required to be corrected shall be removed or, if permitted or required by RurAL CAP, corrected in place by and at the expense of the Contractor promptly after notice, and shall not thereafter be tendered for acceptance unless the former rejection or requirement of correction is disclosed. If the Contractor fails promptly to replace or correct such supplies or lots of supplies, RurAL CAP, either (i) may contract or otherwise replace or correct such supplies and charge to the Contractor the cost occasioned RurAL CAP thereby, or (ii) may terminate this contract for default as provided in the clause of this contract entitled "Default." Unless the Contractor corrects or replaces such supplies within the delivery schedule, RurAL CAP may require the delivery of such supplies at a reduction in price which is equitable under the circumstances. Failure to agree to such reduction of price shall be a dispute concerning a question of fact within the meaning of the clause of this contract entitled "Disputes."
- (c) If any inspection or test is made by RurAL CAP on the premises of the Contractor or a subcontractor, the Contractor without additional charge shall provide all reasonable facilities and assistance for the safety and convenience of RurAL CAP inspectors in the performance of their duties. If RurAL CAP inspection or test is made at a point other than the premises of the contractor or a subcontractor, it shall be at the expense of RurAL CAP except as otherwise provided in this contract, provided, that in case of rejection RurAL CAP shall not be liable for any reduction in value of samples used in

connection with such inspection or test. All inspections and tests by RurAL CAP shall be performed in such a manner as not to unduly delay the work. RurAL CAP reserves the right to charge to the Contractor any additional cost of RurAL CAP inspection and test when supplies are not ready at the time such inspection and test is requested by the Contractor or when reinspection or retest is necessitated by prior rejection. Acceptance or rejection of the supplies shall be made as promptly as practicable after delivery, except as otherwise provided in this contract; but failure to inspect and accept or reject supplies shall neither relieve the Contractor from responsibility for such supplies as are not in accordance with the contract requirements nor impose liability on RurAL CAP therefore.

- (d) Any inspection and test by RurAL CAP of any supplies or lots thereof does not relieve the Contractor from any responsibility regarding defects or other failures to meet the contract requirements which may be discovered prior to acceptance. Except as otherwise provided in this contract, acceptance shall be conclusive except as regards latent defects, fraud, or such gross mistakes as amount to fraud.
- (e) The Contractor shall provide and maintain an inspection system acceptable to RurAL CAP covering the supplies hereunder. Records of all inspection work by the Contractor shall be kept complete and available to RurAL CAP during the performance of this contract and for such longer period as may be specified elsewhere in this contract.

19. FEDERAL, STATE AND LOCAL TAXES:

The Contractor shall pay all federal, state and local taxes incurred and shall require their payment by any subcontractor in the performance of this contract.

- (a) Except as may be otherwise provided in this contract, the contract price includes all applicable federal, state, and local taxes and duties.
- (b) If any federal, state or local excise tax or duty on the transactions or property covered by this contract, by a statute, court decision, written ruling, or regulation takes effect after the contract date, the excess cost must be paid by the contractor and can result in no additional charge to RurAL CAP.
- (c) As used in Paragraph (b) above, the term "Contract Date" means the date set for the bid opening, or, if this is a negotiated contract, the date of this contract. As to additional supplies or services procured by modification to this contract, the term "Contract Date" means the date of such modification.
- (d) Unless there does not exist any reasonable basis to sustain an exemption RurAL CAP, upon request of the Contractor, without further liability, agrees, except as otherwise provided in this contract, to furnish evidence appropriate to establish exception from any tax which the contractor warrants in writing was excluded from the contract price. In addition, RurAL CAP may furnish evidence to establish exemption from any tax that may, pursuant to this clause, give rise to either an increase or decrease in the contract price. Except as otherwise provided in this contract, evidence appropriate to establish exemption duties will be furnished only at the direction of RurAL CAP.

19 A. PRICE REDUCTION FOR DEFECTIVE COST OR PRICING DATA--PRICE ADJUSTMENTS:

- (a) This clause shall become operative only with respect to any modification of this contract which involves aggregate increases and/or decreases in costs plus applicable profits in excess of \$100,000 unless the modification is priced on the basis of adequate price competition, established catalog or market prices of commercial items sold in substantial quantities to the general public, or prices set by law or regulation, the right to price reduction under this clause is limited to defects in data relating to such modification.
- (b) If any price, including profit, or fee, negotiated in connection with any price adjustment under this contract was increased by significant sums because:
 - (1) The Contractor furnished cost or pricing data which was not accurate, complete

- and current in the Contractor's certificate of current cost or pricing data;
- (2) A subcontractor, pursuant to the clause of this contract entitled "subcontractor cost or pricing data" or "subcontractor cost or pricing data--price adjustment: or any subcontract clause therein required, furnished cost or pricing data which was not accurate, complete and current as certified in the subcontractor's certificate or current cost or pricing data;
 - (3) A subcontractor or prospective subcontractor furnished cost or pricing data which was required to be accurate, complete and current and to be submitted to support a subcontract cost estimate furnished by the Contractor but which was not accurate, complete and current as of the date certified in the Contractor's certificate of current cost or pricing data; or
 - (4) The Contractor or a subcontractor or prospective subcontractor furnished any data, not within (1), (2), or (3) above which was not accurate, as submitted, the price shall be reduced accordingly and the contract shall be modified in writing as may be necessary to reflect such reduction. However, any reduction in the contract price due to defective subcontract data of a prospective subcontractor will be limited to the amount (plus applicable overhead and profit markup) by which the actual subcontract or actual cost to the Contractor was less than the prospective subcontract cost estimate submitted by the Contractor: provided the actual subcontract price was not affected by defective cost or pricing data.

(Note: Since the contract is subject to reduction under this clause by reason of defective cost or pricing data submitted in connection with certain subcontracts, it is expected that the Contractor may wish to include a clause in each such subcontract requiring the subcontractor to appropriately indemnify the Contractor. It is also expected that any subcontractor subject to such indemnification will generally require substantially similar indemnification for defective cost or pricing data required to be submitted by his lower tier subcontractors.)

- (c) Cost or pricing data. If the Contractor submitted cost or pricing data in connection with the pricing of this contract or any change or modification thereto unless such pricing was based on adequate price competition, established catalog or market prices of commercial items sold in substantial quantities to the general public or prices set by law, or regulation, RurAL CAP or its representative who are employees of RurAL CAP shall have the right to examine all books, records, documents and other data of the Contractor related to the negotiation, pricing or performance of such contract, change or modification for the purpose of evaluating the accuracy, completeness and currency of the cost or pricing data submitted. The right of examination shall extend to all documents necessary to permit adequate evaluation of the cost or pricing data submitted, along with the computation and projections used therein.
- (d) Availability. The materials described in (b) and (c) above, shall be made available at the office of the Contractor, at all reasonable times, for inspection audit or reproduction until the expiration of 3 years from the date of final payment under this contract or such lesser time specified in part 1-20 of the Federal Procurement Regulations (41 CFR Part 1-20) and for such longer period, if any as is required by applicable statute, or by other clauses of this contract, or by (1) and (2) below:
 - (1) If this contract is completely or partially terminated, the records relating to the work terminated shall be made available for a period of 3 years from the date of any resulting final settlement.

(2) Records which relate to appeals under the "Disputes" clause of this contract, or litigation or the settlement of claims arising out of the performance of this contract shall be made available until such appeals, litigation, or claims have been disposed of.

(e) The Contractor shall insert a clause containing all the provisions of this clause, including this paragraph (e) in all subcontracts hereunder except altered as necessary for proper identification of the contracting parties and RurAL CAP under the RurAL CAP prime contract.

19 B. SUBCONTRACTOR COST OR PRICING DATA:

(a) The Contractor shall require subcontractors hereunder to submit actually or by specific identification in writing, cost or pricing data under the following circumstances:

(1) Prior to the award of any subcontract the amount of which is expected to exceed \$100,000 when entered into;

(2) Prior to the pricing of any subcontract modification which involves aggregate increases and/or decreases in costs plus applicable profits expected to exceed \$100,000; except where the price is based on adequate price competition, established catalog or market prices of commercial items sold in substantial quantities to the general public, or prices set by law or regulation.

(b) The Contractor shall require subcontractors to certify, in substantially the same form as that used in the certificate by the prime contractor to RurAL CAP, that to the best of their knowledge and belief, the cost and pricing data submitted under (a) above is accurate, complete, and current as of the date of agreement on the negotiated price of the subcontract or subcontract change or modification.

(c) The contractor shall insert the substance of this clause including this paragraph (c) in each subcontract hereunder which exceeds \$100,000 when entered into except where the prices thereof is based on adequate price competition, established catalog or market prices of commercial items sold in substantial quantities to the general public, or prices set by law or regulation, in each such excepted subcontract hereunder in excess of \$100,000, the Contractor shall insert the substance of the following clause.

19 C. SUBCONTRACTOR COST OR PRICING DATA--PRICE ADJUSTMENTS:

(a) Paragraph (b) and (c) of this clause shall become operative only with respect to any modification made pursuant to one or more provisions of this contract which involves aggregate increases and/or decreases in costs plus applicable profit expected to exceed \$100,000. The requirements of this clause shall be limited to such modifications.

(b) The Contractor shall require subcontractors hereunder to submit cost or pricing data under the following circumstances:

(1) Prior to the award of any subcontract the amount of which is expected to exceed \$100,000 when entered into;

(2) Prior to the pricing of any subcontract modification which involves aggregate increases and/or decreases in costs plus applicable profits expected to exceed \$100,000; except where the price is based on adequate price competition established catalog or market prices of commercial items sold in substantial quantities to the general public, or prices set by law or regulation.

(c) The Contractor shall require subcontractors to certify that to the best of their knowledge and belief the cost or pricing data submitted under (b) above is accurate, complete, and current as of the date of agreement on the negotiated price of the subcontract or subcontract change or modification.

(d) The Contractor shall insert the substance of this clause including this paragraph (d) in each subcontract which exceeds \$100,000.

20. INDEMNIFICATION:

- (a) The contractor shall indemnify, save harmless and defend RurAL CAP, the state of Alaska, Alaska Housing Finance Corporation, their officers, agents and employees from all liability, including costs and expenses, for all actions or claims resulting from injuries or damages sustained by any person or property arising directly or indirectly as a result of any error, omission or negligent act of the contractor, subcontractor or anyone directly or indirectly employed by them in the performance of this contract.
- (b) All actions or claims including costs and expenses resulting from injuries or damages sustained by any person or property arising directly or indirectly from the contractor's performance of this contract which are caused by the joint negligence of RurAL CAP and/or the state and the contractor shall be apportioned on a comparative fault basis. Any such joint negligence on the part of RurAL CAP and/or the state must be a direct result of active involvement by RurAL CAP and/or the state.
- (c) It is agreed that the Contractor will maintain in force at all times during the performance of the services under this Agreement the following policies of insurance:

Workers' Compensation Insurance: The contractor shall provide and maintain, for all employees of the contractor engaged in work under this contract, Workers' Compensation Insurance as required by AS 23.30.045. The contractor shall be responsible for Workers' Compensation Insurance for any subcontractor who directly or indirectly provides services under this contract. This coverage must include statutory coverage for states in which employees are engaging in work and employer's liability protection not less than \$1,000,000 per person, \$1,000,000 per occurrence.

Comprehensive (Commercial) General Liability Insurance: The Contractor will provide and maintain Comprehensive (Commercial) General Liability Insurance with coverage limits not less than \$1,000,000 combined single limit per occurrence and annual aggregates where generally applicable and will include premises-operation, products/completed operation, broad form property damage, blanket contractual and personal injury coverage.

Comprehensive Automobile Liability Insurance: The Contractor will provide and maintain Comprehensive Automobile Liability Insurance covering all owned, hired, and non-owned vehicles with coverage limits not less than \$1,000,000 per person/\$1,000,000 per occurrence bodily injury and \$1,000,000 property damage or \$1,000,000 combined single limit per accident.

Professional Liability Insurance: If applicable, the Contractor will provide and maintain Professional Liability Insurance covering all errors, omissions or negligent acts of the Contractor, its subcontractors or anyone directly or indirectly employed by them, made in the performance of this Agreement which results in financial loss to the State.

Limits required are per the following schedule:

Contract Amount	Minimum Required Limits
Less than \$100,000	\$100,000 per occurrence/annual aggregate
\$100,000 - \$499,999	\$250,000 per occurrence/annual aggregate
\$500,000 - \$999,999	\$500,000 per occurrence/annual aggregate

- (d) Insurance policies required to be maintained by the Contractor will name Rural Alaska Community Action Program, Inc. (RurAL CAP), Alaska Housing Finance Corporation (AHFC) and the State of Alaska as additional insures.
- (e) The Contractor agrees to obtain a waiver, where applicable, of all subrogation rights against RurAL CAP and AHFC, its officers, officials, employees and volunteers for losses arising from work performed.
- (f) The Contractor will provide Certificates of Insurance stating the Insurance Company, type of coverage, limits, effective date, expiration date, additional insured and waiver of subrogation and must provide for a thirty (30) day prior notice of cancellation, non-renewal or material change to the policy.

21. ADDITIONAL BOND SECURITY:

If any surety upon any bond furnished in connection with this contract becomes unacceptable to RurAL CAP or if any such surety fails to furnish reports as to the financial condition from time to time as requested by RurAL CAP, the Contractor shall promptly furnish all additional security as may be required from time to time to protect the interests of RurAL CAP and of persons supplying labor or materials in the prosecution of the work contemplated by this contract.

22. OFFICIALS NOT TO BENEFIT:

No member of or delegate to Congress, or the legislature or officials or employees of the State or Federal government shall be admitted to any share or part of this contract, or to any benefit that may arise therefrom. This does not preclude officials or employees from sharing in the common benefits of this contract.

23. COVENANT AGAINST CONTINGENT FEES:

The Contractor warrants that no person or selling agent has been employed or retained to solicit or secure this contract upon an agreement or understanding for a commission, percentage, brokerage, or contingent fee, excepting bona fide employees or bona fide established commercial or selling agencies maintained by the Contractor for the purpose of securing business. For breach or violation of this warranty RurAL CAP shall have the right to terminate this contract without liability or in its discretion to deduct from the contract price or consideration, or otherwise recover, the full amount of such commission, percentage, brokerage, or contingent fee.

24. ETHICAL CONDUCT:

The Contractor, subcontractors, and any person(s) performing work on the Contractor's behalf will refrain from any unethical, unfair or deceptive conduct, act or practice, including but not limited to the following:

- (a) Providing false or misleading information regarding the low-income Weatherization Program;
- (b) Promoting or selling a product by brand name, except when the brand name is generally accepted as a generic name, during or in connection with performance under this program;
- (c) Promoting a service by a specific person or company during or in connection with this program;
- (d) Breaching the person's right to privacy or the obligation of confidentiality; or
- (e) Engaging in an action or behavior for the purpose of obtaining reimbursement for work not performed, not approved, or performed in violation of the laws, regulations, and prescribed procedures for this program.

25. DISSEMINATION OF INFORMATION:

Prior approval shall be obtained from RurAL CAP for the release or dissemination of information related to this contract.

"Information" includes, but is not limited to news releases, articles, manuscripts, reports, advertisements, still and motion pictures, speeches, trade association meetings, symposia, etc. Requests for approval should be forwarded three weeks in advance of desired release date to permit sufficient time for review, evaluation, and clearance. RurAL CAP will be responsible for obtaining any necessary governmental clearance.

26. DISPUTES:

- (a) Except as otherwise provided in this contract, any dispute concerning a question of fact arising under this contract which is not disposed of by agreement shall be decided by RurAL CAP, who shall reduce the decision to writing and mail or otherwise furnish a copy thereof to the Contractor. The decision of RurAL CAP shall be final and conclusive. Pending final decision of a dispute hereunder, the Contractor shall proceed diligently with the performance of the contract and in accordance with RurAL CAP's decision.
- (b) This "Disputes" clause does not preclude consideration of law questions in connection with decisions provided for in paragraph (a) above, provided that nothing in this contract shall be construed as making final the decision of any administrative official, representative, or board on a question of law.

27. DEFAULT:

- (a) Subject to the provisions of paragraph (d) below, any late delivery of materials shall subject the contractor to liquidated damages in the amount of 1% of the total bid price for each day of delay. By acceptance of the contract hereunder, the contractor agrees that damages for delay are difficult to calculate, and agrees to the foregoing liquidated damage provision as the agreed deduction for delay damages, and not as a penalty. This paragraph is included in this solicitation in order to partially offset the serious consequences, financial, and personal, which may be borne by RurAL CAP and the communities from any delay in performance hereunder by any contractor.
- (b) RurAL CAP may in lieu of invoking paragraph (a) and subject to the provisions of paragraph (d) below, by written notice of default to the Contractor, terminate the whole or any part of this contract in any one of the following circumstances:
 - (1) If the Contractor fails to make delivery of the supplies or to perform the services within the time specified herein or any extension thereof; or
 - (2) If the Contractor fails to perform any of the other provisions of this contract, or so fails to make progress as to endanger performance of this contract in accordance with its terms, and in either of these two circumstances does not cure such failure within a period of 10 days (or such longer period as RurAL CAP may authorize in writing) after receipt of notice from RurAL CAP specifying such failure.
- (c) In the event RurAL CAP terminates this contract in whole or in part as provided in paragraph (b) of this clause, RurAL CAP may procure, upon such terms and in such manner as RurAL CAP deems appropriate, supplies or services similar to those so terminated, and the Contractor shall be liable to RurAL CAP for any excess costs for such similar supplies or services, provided that the Contractor shall continue the performance of this contract to the extent not terminated under the provisions of this clause.

- (d) Except with respect to defaults of subcontractors, the Contractor shall not be liable for any excess costs if the failure to perform the contract arises out of causes beyond the control and without the fault or negligence of the Contractor. Such causes may include, but are not restricted to, acts of God or of the public enemy, acts of RurAL CAP in either its sovereign or contractual capacity, fires, floods, epidemics, quarantine restrictions, strikes, freight embargoes, and unusually severe weather; but in every case the failure to perform must be beyond the control and without the fault or negligence of the Contractor. If the failure to perform is caused by the default of a subcontractor, and if such default arises out of causes beyond the control of both the Contractor and subcontractor, and without the fault or negligence of either of them, the Contractor shall not be liable for any excess costs for failure to perform, unless the supplies or services to be furnished by the subcontractor were obtainable from other sources in sufficient time to permit the Contractor to meet the required delivery schedule.
- (e) If the contract is terminated as provided in paragraph (b) of this clause, RurAL CAP, in addition to any other rights provided in this clause, may require the Contractor to transfer title and deliver to RurAL CAP, in the manner and to the extent directed by RurAL CAP, (i) any completed supplies, and (ii) such partially completed supplies and materials, parts, tools, dies, jigs, fixtures, plans, drawings, information, and contract rights (hereinafter called "manufacturing materials") as the Contractor has specifically produced or specifically acquired for the performance of such part of this contract as has been terminated; and the Contractor shall, upon direction of RurAL CAP protect and preserve property in possession of the Contractor in which RurAL CAP has an interest. Payment for completed supplies delivered to and accepted by RurAL CAP shall be at the contract price. Payment for manufacturing materials delivered to and accepted by RurAL CAP and for the protection and preservation of property shall be in an amount agreed upon by the Contractor and Contracting Officer. Failure to agree to such amount shall be a dispute concerning a question of fact within the meaning of the clause of this contract entitled "Disputes." RurAL CAP may withhold from amounts otherwise due the Contractor for such completed supplies or manufacturing materials such sum as RurAL CAP determines to be necessary to protect RurAL CAP against loss because of outstanding liens or claims of former lien holders.
- (f) If, after notice of termination of this contract under the provisions of this clause, it is determined for any reason that the Contractor was not in default under the provisions of this clause, or that the default was excusable under the provisions of this clause, the rights and obligations of the parties shall, if the contract contains a clause entitled "Termination for Convenience of RurAL CAP", be the same as if the notice of termination had been issued pursuant to such clause. If, after notice of termination of this contract under the provisions of this clause it is determined for any reason that the Contractor was not in default under the provisions of this clause, and if this contract does not contain a clause entitled "Termination for Convenience of RurAL CAP," the contract shall be equitably adjusted to compensate for such termination and the contract modified accordingly; failure to agree to any such adjustment shall be a dispute concerning a question of fact within the meaning of the clause of this contract entitled "Disputes."
- (g) The rights and remedies of RurAL CAP provided in this clause shall not be exclusive and are in addition to any other rights and remedies provided by law or under this contract.
- (h) As used in paragraph (d) of this clause, the terms "subcontractors" means subcontractor(s) at any tier.

28. TERMINATION FOR CONVENIENCE OF RURAL CAP:

- (a) The performance of work under this contract may be terminated by RurAL CAP, in accordance with the clause in whole, or from time to time in part, whenever RurAL CAP shall determine that such termination is in the best interest of RurAL CAP. Any such termination shall be effected by delivery to the Contractor of a notice of termination specifying the extent to which performance of work under the contract is terminated, and the date upon which such termination becomes effective.

(b) After receipt of a notice of termination, and except as otherwise directed by RurAL CAP, the Contractor shall:

- (1) Stop work under the contract on the date and to the extent specified in the notice of termination;
- (2) Place no further orders or subcontracts for materials, services, or facilities, except as may be necessary for completion of such portion of the work under the contract as is not terminated;
- (3) Terminate all orders and subcontracts to the extent that they relate to the performance of work terminated by the notice of termination;
- (4) Assign to RurAL CAP to the extent directed by RurAL CAP, all of the right, title, and interest of the Contractor under the orders and subcontracts so terminated, in which case RurAL CAP, shall have the right, in its discretion, to settle or pay any or all claims arising out of the termination of such orders and subcontracts;
- (5) Settle all outstanding liabilities and all claims arising out of such termination of orders and subcontracts, with the approval or ratification shall be final for all the purposes of this clause;
- (6) Transfer title to RurAL CAP, and deliver in the manner at the times, and to the extent, if any, directed by RurAL CAP, (I) the fabricated or unfabricated parts, work in process, completed work, supplies, and other material produced as a part of, or acquired in connection with the performance of, the work terminated by the notice of termination, and (II) the completed or partially completed plans, drawings, information and other property which, if the contract has been completed, would have been required to be furnished to RurAL CAP;
- (7) Use its best efforts to sell in the manner, at the times, to the extent and at the price or prices directed or authorized by RurAL CAP, any property of the types referred to in (6) above, provided, however, that the Contractor (I) shall not be required to extend credit to any purchaser, and (II) may acquire any such property under the conditions prescribed by and at a price or prices approved by RurAL CAP, and provided further that the proceeds of any such transfer or disposition shall be applied in reduction of any payments to be made by RurAL CAP to the Contractor under this contract or shall otherwise be credited to the price or cost of the work covered by this contract or paid in such other manner as RurAL CAP may direct;
- (8) Complete performance of such part of the work as shall not have been terminated by the notice of termination; and
- (9) Take such action as may be necessary, or as RurAL CAP may direct, for the protection and preservation of the property related to this contract which is in the possession of the Contractor and in which RurAL CAP has or may acquire an interest.

At any time after expiration of the plant clearance period, as defined in subpart 1-8.1 of the Federal Procurement Regulations (41 CFR 1-8.1), as the definition may be amended from time to time, the Contractor may submit to RurAL CAP a list, certified as to quantity and quality, of any or all items of termination inventory not previously disposed of. Exclusive of items the disposition of which has been directed or authorized by RurAL CAP, any Contractor may request RurAL CAP to remove such items or enter into a storage agreement covering them. Not later than fifteen (15) days thereafter, RurAL CAP will accept title to such items and remove them or enter into a storage agreement covering the same, provided that the list submitted shall be subject to verification by RurAL CAP upon removal of the items, or if the items are stored, within forty-five (45) days from the date of submission of the list, and any necessary adjustment to correct the list as submitted shall be made prior to final settlement.

(c) After receipt of a notice of termination, the Contractor shall submit to RurAL CAP the termination claim, in the form and with certification prescribed by RurAL CAP. Such claim shall be submitted promptly but in no event later than one year from the effective date of termination, unless one or more extensions in writing are granted by RurAL CAP upon request of the Contractor made in writing within such one-year period or authorized extension thereof. However, if RurAL CAP determines that the facts justify such action, it may receive and act upon any such termination

claim at any time after such one-year period or any extension thereof. Upon failure of the Contractor to submit his termination claim within the time allowed, RurAL CAP may, subject to any review required by the Contracting Agency's procedures in effect as of the date of execution of this contract, determine, on the basis of information available to him, the amount, if any, due to the Contractor by reason of the termination and shall thereupon pay to the Contractor the amount so determined.

- (d) Subject to the provisions of paragraph (c), and subject to any review required by the Contracting Agency's procedures in effect as of the date of execution of this contract, the Contractor and RurAL CAP may agree upon the whole or any part of the amount or amounts to be paid to the Contractor by reason of the total or partial termination of work pursuant to this clause, which amount or amounts may include a reasonable allowance for profit on work done, provided that such agreed amount or amounts, exclusive of settlement costs, shall not exceed the total, contract price as reduced by the amount of payments otherwise made and as further reduced by the contract price of work not terminated. The contract shall be amended accordingly and the Contractor shall be paid the agreed amount. Nothing in paragraph (e) of this clause, prescribing the amount to be paid to the Contractor in the event of failure of the Contractor by reason of the termination of work pursuant to this clause, shall be deemed to limit, restrict, or otherwise determine or "affect the amount or amounts which may be agreed upon to be paid to the Contractor pursuant to this paragraph (d).
- (e) In the event of the failure of the Contractor and RurAL CAP to agree, as provided in paragraph (d), upon the whole amount to be paid to the Contractor or by reason of the termination of work pursuant to this clause, RurAL CAP shall, subject to any review required by the Contracting Agency's procedures in effect as of the date of execution of this contract, determine, on the basis of information available the amount, if any, due to the Contractor by reason of the termination and shall pay to the Contractor the amounts determined as follows:
 - (1) For completed supplies accepted by RurAL CAP, (or sold or acquired as provided in paragraph (b) (7) above) and not theretofore paid for, a sum equivalent to the aggregate price for such supplies computed in accordance with the price or prices specified in the contract, appropriately adjusted for any saving of freight or other charges;
 - (2) The total of:
 - (I) The costs incurred in the performance of the work terminated, including initial costs preparatory expense allocable thereto, but exclusive of any costs attributable to supplies paid or to be paid for under Paragraph (e) (1) hereof;
 - (II) The cost of settling and paying claims arising out of the termination of work under subcontracts or orders, as provided in Paragraph (b) (5) which are properly chargeable to the terminated portion of the contract (exclusive of amounts paid or payable on account of supplies or materials delivered or services furnished by subcontractors or vendors prior to the effective date of the notice of termination, which amounts shall be included in the costs payable under (1) above); and
 - (III) A sum, as profit on (I) above determined by RurAL CAP to be fair and reasonable, provided, however, that if it appears that the Contractor would have sustained a loss on the entire contract had it been completed, profit shall not be included or allowed under this subdivision (III) and an appropriate adjustment shall be made reducing the amount of the settlement to reflect the indicated rate of loss; and
 - (3) The costs reasonably necessary for the preparation of settlement claims and supporting data with respect to the terminated portion of the contract and for termination and settlement of subcontracts thereunder, together with reasonable storage, transportation, and other costs incurred in connection with the protection or disposition of property allocable to this contract;

The total sum to be paid to the contractor under (1) and (2) of this paragraph (e) Shall not exceed the total contract price as reduced by the amount of payments otherwise made and as further reduced by the contract price of work not terminated. Except for normal spoilage, and except to the extent that RurAL CAP shall have otherwise expressly assumed the risk of loss, there shall be excluded from the amount payable to the Contractor as provided in (e) (1) and

(2) above, the fair value, as determined by RurAL CAP, of property which is destroyed, lost, stolen, or damaged so as to become undeliverable to RurAL CAP, or to a buyer pursuant to paragraph (B) (7)

- (f) The Contractor shall have the right to appeal, under the clause of this contract entitled "Disputes", from any determination made by RurAL CAP under paragraph (c) or (e) above, except that, if the Contractor has failed to submit a claim within the time provided in paragraph (c) above and has failed to request extension of such time, they shall have no such right of appeal. In any case where RurAL CAP has made a determination of the amount due under paragraph (c) or (e) above, RurAL CAP shall pay to the Contractor the following: If there is no right or appeal hereunder or if no timely appeal has been taken, the amount finally determined on such appeal.
- (g) In arriving at the amount due the Contractor under this clause there shall be deducted (1) all unliquidated advance or other payments on account theretofore made to the Contractor, applicable to the terminated portion of this contract; (2) any claim which RurAL CAP, may have against the Contractor in connection with this contract; and (3) the agreed price for, or the proceeds of sale of, any materials, supplies, or other things acquired by the Contractor or sold, pursuant to the provisions of this clause, and not otherwise recovered by or credited to RurAL CAP.
- (h) If the termination hereunder be partial, prior to the settlement of the terminated portion of this contract, the Contractor may file with RurAL CAP a request in writing for an equitable adjustment of the price or prices specified in the contract relating to the continued portion of the contract (the portion not terminated by the notice of termination), and such equitable adjustment as may be agreed upon shall be made in such price or prices.
- (i) RurAL CAP may from time to time, under such terms and conditions as it may prescribe, make partial payments and payments on account against costs incurred by the Contractor in connection with the terminated portion of this contract whenever in the opinion of RurAL CAP the aggregate of such payments shall be within the amount to which the Contractor will be entitled hereunder. If the total of such payments is in excess of the amount finally agreed or determined to be due under this clause, such excess shall be payable by the Contractor to RurAL CAP upon demand, together with interest computed at the rate of 6 percent per annum for the period from the date such excess payment is received by the Contractor to the date on which such excess is repaid to RurAL CAP, provided, however, that no interest shall be charged with respect to any such excess payment attributable to a reduction in the Contractor's claim by reason of retention or other disposition of termination inventory until ten days after the date of such retention or disposition, or such later date as determined by RurAL CAP of the circumstances.
- U) Unless otherwise provided for in this contract, or by applicable statute, the Contractor, from the effective date of termination and for a period of three years after final settlement under this contract, shall preserve and make available to RurAL CAP, at all reasonable times at the office of the Contractor but without direct charge to RurAL CAP, all his books, records, documents, and other evidence bearing on the costs and expenses of the Contractor under this contract and relating to the work terminated hereunder, or; to the extent approved by RurAL CAP, photographs, microphotographs or other authentic reproductions thereof.

29. GOVERNING LAW:

This contract shall be governed by and construed in accordance with Alaska Law, and the venue of any action brought with respect to any such contract shall be in the Alaska State or Federal Courts. Contractor shall perform all activities under this contract in compliance with all appropriate laws. The contractor or any subcontractor is required to hold a current Alaska business license as required by

Alaska Statute. All permits, licenses, etc. required by the Contractor for the performance of this contract shall be obtained by the contractor prior to commencement of any work.

30. INCORPORATION BY REFERENCE:

Definitions; Instructions to Bidders; General Terms and Conditions; Compliance and Certifications; Standard Procedures; Listing of Materials/Services Required; Solicitation Offer and Award; Additional Provisions and all Attachments to this Contract are hereby incorporated into and made a part of this Contract.

31. ORDER OF PRECEDENCE:

In the event of an inconsistency between provisions of this solicitation, the inconsistency shall be resolved by giving precedence in the following order: (a) solicitation offer and award; (b) the listing of materials/services required; (c) Definitions and Instructions to Bidders; (d) General Terms and Conditions; (e) Compliance and Certifications.

32. ACCESS TO RECORDS:

- (a) The Contractor agrees that the State of Alaska, U.S. Department of Energy, The Comptroller General of the United States or any of its duly authorized representatives shall have access to and the right to examine any directly pertinent books, documents, papers, and records of the Contractor and any subcontractors involving transactions related to this contract during normal business hours. This access to records shall be for the purpose of audit, examination, excerpt and transactions.
- (b) The contractor and any subcontractors shall maintain all required records for three (3) years after the final payment is made and all other pending matters from audit, litigation or action involving the records are resolved.

APPENDIX D

COMPLIANCE AND CERTIFICATIONS

33. UTILIZATION OF SMALL BUSINESS CONCERNS:

- (a) Positive efforts shall be made by RurAL CAP to provide opportunity for competitive bid and to utilize small business sources for supplies and services.
- (b) The Contractor agrees to use positive efforts to carry out this policy in the award of subcontracts to the fullest extent consistent with the efficient performance of this contract.

34. UTILIZATION OF LABOR SURPLUS AREA CONCERNS:

- (a) Positive efforts shall be made by RurAL CAP to procure supplies and services from labor surplus areas.
- (b) The contractor agrees to use positive efforts to procure supplies and services from surplus areas in the award of subcontracts to the fullest extent consistent with the efficient performance of this contract.

35. UTILIZATION OF MINORITY BUSINESS CONCERNS:

- (a) Positive efforts shall be made by RurAL CAP to provide opportunity for competitive bid and to utilize minority business sources for supplies and services.
- (b) The Contractor agrees to use positive efforts to carry out this policy in the award of subcontracts to the fullest extent consistent with the efficient performance of this contract.

36. UTILIZATION OF WOMEN'S BUSINESS CONCERNS:

- (a) Positive efforts shall be made by RurAL CAP to provide opportunity for competitive bid and to utilize women's business sources for supplies and services.
- (b) The Contractor agrees to use positive efforts to carry out this policy in the award of subcontracts to the fullest extent consistent with the efficient performance of this contract.

37. EQUAL OPPORTUNITY :

- (a) The Contractor may not discriminate against any employee or applicant for employment because of race, religion, color, national origin, or because of age, physical handicap, sex, marital status, change in marital status, pregnancy or parenthood when the reasonable demands of the positions do not require distinction on the basis of age, physical handicap, sex, marital status, changes in marital status, pregnancy, or parenthood. The Contractor shall take affirmative action to insure that applicants are considered for employment and that employees are treated during employment without unlawful regard to their race, color, religion, national origin, ancestry, physical handicap, age, sex, marital status, changes in marital status, pregnancy or parenthood. This action must include, but need not be limited to, the following:

Employment, upgrading, demotion, transfer, recruitment or recruitment advertising, layoff or termination, rates or pay or other forms of compensation, and selection for training including apprenticeship. The Contractor shall post in conspicuous places, available to employees and applicants for employment, notices setting out the provisions of this paragraph.

- (b) The Contractor shall state, in all solicitations or advertisements for employees to work on State of Alaska contract jobs, that it is an equal opportunity employer and that all qualified applicants will receive consideration for employment without regard to race, religion, color, national origin, age, physical handicap, sex, marital status, changes in marital status, pregnancy or parenthood.
- (c) The Contractor shall send to each labor union or representative of workers with which the Contractor has a collective bargaining agreement or other contract or understanding a notice advising the labor union or workers' compensation representative of the Contractor's commitments under this article and post copies of the notice in conspicuous places available to all employees and applicants for employment.
- (d) The Contractor shall include the provisions of this article in every contract, and shall require the inclusion of these provisions in every contract entered into by any of its subcontractors so that those provisions will be binding upon each subcontractor. For the purpose of including those provisions in any contract or subcontract, as required by this contract, "contractor" and "subcontractor" may be changed to reflect appropriately the name or designation of the parties of the contract or subcontract.
- (e) The Contractor shall cooperate fully with State efforts which seek to deal with the problem of unlawful discrimination, and with all other State efforts to guarantee fair employment practices under this contract, and promptly comply with all requests and directions from the State Commission for Human Rights or any of its officers or agents relating to prevention of discriminatory employment practices.
- (f) Full cooperation in paragraph (e) includes, but is not limited to, being a witness in any proceeding involving questions of unlawful discrimination if that is requested by any official or agency of the State of Alaska; permitting employees of the Contractor to be witnesses or complainants in any proceeding involving questions of unlawful discrimination, if that is requested by any official or agency of the State of Alaska; participating in meetings; submitting periodic reports on the equal employment aspects of present and future employment; assisting inspection of the Contractor's facilities; and promptly complying with all State directives considered essential by any office or agency of the State of Alaska to insure compliance with all federal and state laws, regulations, and policies pertaining to the prevention of discriminatory employment practices.
- (g) Failure to perform under this article constitutes a material breach of the contract.

38. CERTIFICATION FOR CONTRACTS, GRANTS, LOANS, AND COOPERATIVE AGREEMENTS REGARDING LOBBYING:

The Contractor certifies, to the best of his or her knowledge and belief, that:

- (a) No Federal appropriated funds have been paid or will be paid, by or on behalf of the Contractor, to any person for influencing or attempting to influence an officer or employee of any agency, a Member of Congress, an officer or employee of Congress, or an employee of a Member of Congress in connection with the awarding of any Federal contract, the making of any Federal grant, the making of any Federal loan, the entering into of any cooperative agreement, and the extension, continuation, renewal, amendment, or modification of any Federal contract, grant, loan, or cooperative agreement.
- (b) If any funds other than Federal appropriated funds have been paid or will be paid to any person for influencing or attempting to influence an officer or employee of any agency, a Member of Congress, an officer or employee of Congress, or an employee of a Member of Congress in connection with this Federal contract, grant, loan or cooperative agreement, the Contractor shall complete and submit Standard Form-LLL, "Disclosure Form to Report Lobbying," in accordance with its instructions.
- (c) The Contractor shall require that the language of this certification be included in the award documents for all subawards at all tiers (including subcontracts, subgrants, and contracts under grants, loans, and cooperative agreements) and that all subrecipients shall certify and disclose accordingly.

39. CERTIFICATION REGARDING DEBARMENT, SUSPENSION, INELIGIBILITY AND VOLUNTARY EXCLUSION - LOWER TIER COVERED TRANSACTIONS: (To Be Supplied to Lower Tier Participants)

- (a) By signing and submitting this lower tier proposal, the prospective lower tier participant, as defined in 45 CFR Part 76, certifies to the best of its knowledge and belief that it and its principals:
- (1) Are not presently debarred, suspended, proposed for debarment, declared ineligible, or voluntarily excluded from participation in this transaction by any federal department or agency;
 - (2) Where the prospective lower tier participant is unable to certify to any of the above, such prospective participant shall attach an explanation to this proposal.
- (b) The prospective lower tier participant further agrees by submitting this proposal that it will include this clause entitled "Certification Regarding Debarment, Suspension, Ineligibility, and Voluntary Exclusion - Lower Tier Covered Transactions," without modification in all lower tier covered transactions and in all solicitations for lower tier covered transactions.

40. CERTIFICATION REGARDING DRUG-FREE WORKPLACE REQUIREMENTS:

The Contractor, in accordance with The Drug Free Workplace Act of 1988, 45 CFR Part 76, Subpart F, certifies that it will provide a drug-free workplace by:

- (a) Publishing a statement notifying employees that the unlawful manufacture, distribution, dispensing, possession or use of a controlled substance is prohibited in the Contractor's workplace and specifying the actions that will be taken against employees for violation of such prohibition;
- (b) Establishing a drug-free awareness program to inform employees about:
- (1) The dangers of drug abuse in the workplace;
 - (2) The Contractor's policy of maintaining a drug-free workplace;
 - (3) Any available drug counseling, rehabilitation, and employee assistance programs; and
 - (4) the penalties that may be imposed upon employees for drug abuse violations occurring in the workplace;
- (c) Making it a requirement that each employee to be engaged in the performance of this contract be given a copy of the statement required by paragraph (a), above;
- (d) Notifying the employee in the statement required by paragraph (a), above, that, as a condition of employment under this contract, the employee will:
- (1) Abide by the terms of the statement; and
 - (2) Notify the employer of any criminal drug statute conviction for a violation occurring in the workplace no later than five days after such conviction;
- (e) Notifying RurAL CAP within ten days after receiving notice under subparagraph (d) (2), above, from an employee or otherwise receiving actual notice of such conviction;
- (f) Taking one of the following actions, within 30 days of receiving notice under subparagraph (d) (2), above, with respect to any employee who is so convicted:
- (1) Taking appropriate personnel action against such an employee, up to and including termination; or
 - (2) Requiring such employee to participate satisfactorily in a drug abuse assistance or rehabilitation program approved for such purposes by a Federal, State, or local health, law enforcement, or other appropriate agency;

- (g) Making a good faith effort to continue to maintain a drug-free workplace through implementation of paragraphs (a), (b), (c), (d), (e), and (f), above.

41. CERTIFICATE OF INDEPENDENT PRICE DETERMINATION:

By submission of this bid, the bidder certifies and in the case of a joint bid, each party thereto certifies as to its own organizations, that in connection with this procurement:

- (a) The prices in this bid have been arrived at independently, without consultation, communication or agreement, for the purpose of restricting competition, as to any matter relating to such prices with any other bidder or with a competitor;
- (b) Unless otherwise required by law, the prices which have been quoted in this bid have not been knowingly disclosed by the bidder and will not knowingly be disclosed by the bidder prior to bid opening, directly or indirectly to any other bidder or to any competitor;
- (c) No attempt has been made or will be made by the bidder to induce any person or firm to submit or not to submit, a bid for the purpose of restricting competition.
- (d) Each person signing this bid certifies that:
 - (1) They are the person in the bidder's organization responsible within that organization for the decision as to the prices being offered herein and that they have not participated, will not participate, in any action contrary to the paragraphs above; or
 - (2) They are not the person in the bidder's organization responsible within that organization for the decision as to the prices being offered herein but they have been authorized in writing to act as agent for the persons responsible for such decision in certifying that such persons have not participated and will not participate, in any action contrary to the paragraphs above, and as their agent does so certify.

(continued on next page)

42. The Grantee and any Subcontractor is Subject to the following laws, regulations, program guidelines and reference materials. Copies are available for review at the State office. Any omission of an applicable regulation does not preclude its applicability.
- 42.1. Reimbursable Services Agreement between the Department of Community and Regional Affairs and the Department of Health & Social Services for expending LIHEAP funds for the current State fiscal year;
- 42.2. Privacy Act of 1974, PL 93-589; The Grantee and any subgrantee can not maintain information about any individual in a manner which would violate the provisions of this Act;
- 42.3. 10 CFR 600, Financial Assistance Rules; To establish uniform policies and procedures for financial management for any entity receiving federal funds;
- 42.4. OMB Circular A-110; Establishes uniform administrative requirements for grants and other agreements with institutions of higher education, hospitals, and other non-profit organizations
- 42.5. OMB Circular A-122, Cost Principles Applicable to Grants, Contracts, and Other Agreements with Nonprofit Organization.
- 42.6. OMB Circular A-133; Audits of Institutions of Higher Education and other Non-Profit Organization.
- 42.7. PL 87-581, "Work Hours Act of 1962 (40 USC 327-333,1449)" ;
- 42.8. PL 88-352, Title IV, "Civil Rights Act of 1964 (42 USC2000d)";
- 42.9. PL 90-284, "Title VIII,
- "Civil Rights Act of 1968 (42 USC 3601-3619)";
- 42.10. PL 91-190, "National Environmental Policy Act of 1969 (16 USC 17k; 42 USC 4231, 4331-4335, 4341-4347);
- 42.11. PL 91-604, Section 1. "Clean Air Act of 1970 (42 USC 1857b)";
- 42.12. PL 91-616, "Comprehensive Alcohol Abuse and Alcoholism Prevention, Treatment, and Rehabilitation Act of 1970, (42 USC 218, 246, 290aa-dd, 2688h, t; 4541-4542, 4551 note, 4552-4553, 4586, 4591-4594);
- 42.13. PL 92-255, "Drug Abuse Office and Treatment Act of 1972(21 USA 290, 1101 note, 1101-1104,111-1117, 1121-1123, 1131-1143, 1151-1155, 1161-1165, 1171, 1172, 1176-1181, 1194; 42 USC 246, 257, 290aa-2, 290cc,290ee,2684,2688a,2688k, 2688n-1, 2688t);
- 42.14. PL 92-318, "Title IX, Education Amendments of 1972 (20 USC 1681-1683, 1685-1686);
- 42.15. PL 93-112, "Section 504, Rehabilitation Act of 1973 (29 USC 794);
- 42.16. PL 93-234, "Section 102a, Flood Disaster Protection Act of 1973 (42 USC 4012a);
- 42.17. PL 93-291, "Section 1 (s) Archaeological and Historic Preservation Act of 1974 (16 USC 469a-1--a-3);
- 42.18. PL 94-135, "Title 111, Age Discrimination Act of 1975 (42 USC 6101-6107)";
- 42.19. PL 96-511, "Section 2a & 5, Paperwork Reduction Act of 1980 (44 USC 3501)";
- 42.20. PL 98-502, "Single Audit Act of 1984 (31 USC 7501 note, 7501-7507);

- 42.18. PL 98-558, "Title IV, Human Services Reauthorization Act of 1984 (42 USC 6862, 6865)";
- 42.22. PL 99-603, "Section 201 & 303, Immigration Reform and Control Act, 1986 (8 USC 1161, 1251(a)(18), (19), (20), 1255(a), 42 USC 602(f), 672(a), 673(a)(1))";
- 42.23. PL 101-121, "Section 319, (Byrd Amendment, 1989)(31 USC 1352)";
- 42.24. PL 101-136, "Section 623(a), Treasury, Postal Service and General Government Appropriations Act, 1990 (Stevens Amendment)"
- 42.25. 5 USC 1501-1508, 7324-7328, "Hatch Political Activities Act, 1939, as amended.;
- 42.26. 18 USC 874, 40 USC 276c Copeland Act of 1934, as amended";
- 42.27. 42 USC 290dd-3, 290ee-3, "Public
- ~~4233~~ 45 CFR 96, "Block Grants, revised 10/88 (LIHEAP)";
- ~~4234~~ 48 CFR 931 (FAR, "Contract Cost Principles and Procedures, revised 10/89" (State does not have a copy);
- ~~4235~~ EO 11988, "Floodplan Management, signed 5/77";
- ~~4236~~ A-50, "Audit Follow-up, issued 9/82" ; and
- ~~4242~~ PL 93-205, "Endangered Species Act of 1973
- Health Service Act of 1912, as amended";
- ~~4228~~ 8 CFR 245a.5, "Temporary Disqualification of Certain Newly Legalized Aliens from Receiving Benefits from Federal Programs of Financial Assistance, issued 7/89";
- ~~4229~~ 10 CFR 1036, "Government wide Debarment and Suspension (Nonprocurement), revised 1/89";
- ~~4230~~ 10 CFR 1041, "Non-discrimination in Federally Assisted Programs, revised 1/89" ;
- ~~4231~~ 29 CFR 1910-1926, "Occupational Exposure to Asbestos, Termolite, Anthophyllite, and Actinolite, revised 7/89";
- ~~4232~~ 40 CFR 248 "Guidance for Procurement of Building Insulation Products Containing Recovered Materials, issued 2/89";
- ~~4237~~ A-73, "Audit of Federal Operations and Programs, issued 6/83";
- ~~4238~~ 42 USC "Section 4801, Lead Based Paint Poisoning Prevention Act";
- ~~4239~~ "National Historic Preservation Act of 1966, as amended";
- ~~4240~~ "Wild & Scenic Rivers Act of 1968";
- ~~4241~~ PL 93-523, "Safe Drinking Water Act of 1974";

APPENDIX E

STANDARD PROCEDURES FOR ACQUISITION OF MATERIALS

When RurAL CAP enters into an agreement with the supplier to furnish materials for a particular region or villages is usually in the form of a contract with that supplier. This contract is not only for the purchase of the appropriate materials but for the shipping of those materials from the manufacturing site to the ultimate village destination. In addition, the contracts with the vendors will state that the vendor will be responsible for affixing a packing slip to the materials to each village. The packing slip will show the following

1. The number of containers/crates being shipped.
2. A detailed list of materials shipped within each container/crate/shipment/shipped

The actual purchase of materials for a village or a number of villages will be accomplished through a RurAL CAP Purchase Order. This Purchase Order will have a stamped notation that will read as follows:

"RurAL CAP requires a detailed, itemized packing slip affixed to materials when shipped".

The contractor (vendor/supplier) will notify the RurAL CAP Grant Administrator of the shipping time and ETA that the materials would arrive at the air carrier's dock, fob Anchorage Airport. The Weatherization Program Manager will have an on-site supervisor on RurAL CAP payroll approximately one week prior to the ETA of the materials. The on-site supervisor will be responsible for receiving the materials and performing the appropriate inventory of those materials.

If there are no discrepancies noted on the field document the Grant Administrator will indicate approval on both the invoice and the packing slip and route both documents to Accounting to be paid against the indicated Purchase Order. If all documents are in order, the Accounting Department will process check for payment of those materials. **The Accounting Department will not process payment for any weatherization materials in the absence of an approved packing slip and detailed invoice from the vendor without direct and written approval of the Finance Director prior to the processing of that payment.**

The Contractor is responsible for delivery of the materials to designated Air Carrier at the Ted Stevens International Airport. (The Contractor is not responsible for delivery of materials to each local work site.) The Contractor is also responsible for identifying all doors and windows with village name and client project numbers. This identification will consist of (at least) a piece of masking tape with the home owner's name or project number printed on it and the village name.

APPENDIX F

LISTING OF MATERIALS/SERVICES REQUIRED

The Rural Alaska Community Action Program, Inc. (RurAL CAP) invites you to participate, through the competitive bid process, in the supply for the listed items for the benefit of the Alaskan communities listed in Attachment III, in the estimated quantities shown. The material quantities included in this bid are estimates for approximately 10 homes FY2025 for the village of Koyuk.

WINDOW SPECIFICATIONS (See Attachment II)

QUANTITY, DESCRIPTION LISTING (See Attachment III)

EMAIL bids to Darrel Behymer at dbehym@ruralcap.org and Mike McAlpin at mmcalpin@ruralcap.org

PLEASE SPECIFY BID NUMBER AND TITLE ON THE EMAIL SUBJECT LINE ALONG WITH BIDDER'S NAME.

Bid must include:

1. Appendix G (complete all of the OFFER section, including signature of authorized official)
2. Attachment III, including unit cost and extended cost for all items and freight to FOB.
3. List of References
4. Provide any and all information required in Attachment II, Specifications. Provide information showing materials meet specifications, or at a minimum, a statement that all materials to be supplied will conform to Attachment II, Specifications.

BIDS MUST BE RECEIVED NO LATER THAN 4:30 PM 12/30/2024

Proposal Question

All questions pertaining to this solicitation must be submitted in writing by 12/23/2024. Questions may be emailed to Mike McAlpin mmcalpin@ruralcap.org.

Answers/Amendments to the bid packet will be emailed to all firms who have received the proposal and have provided an email address or to RurAL CAP. To register your email at dbehym@ruralcap.org

APPENDIX G

MUST BE ATTACHED TO BID

Solicitation #: WX2024-003

Solicitation Title: IFB WX2024-003 (Materials)

Issue Date: 12/11/24

Bid Receipt Date and Time: NO LATER THAN 4:30 P.M., Monday 12/30/2024

Bid Must Be Submitted To: Darrel Behymer at dbehymer@ruralcap.org and Mike McAlpin at

mmcalpin@ruralcap.org

Bid Opening Date: 01/02/2025 at 731 E 8th Ave, Anchorage, AK

Anticipated Notification Date: 01/03/2025 Effective Contract Date: April 1, 2025 through March 31, 2026

OFFER

In compliance with the *above*, the undersigned offers and agrees, if this offer is accepted within 30 calendar days from the date for receipt of offer specified *above*, to furnish any and all items upon which prices are offered for the term of this contract.

Name of Bidder: _____ Address: _____ Signature of bidder: _____

Title of bidder: _____

Date Bid Submitted: _____

Employer Identification #: _____

Contact Name: _____ Contact phone#: _____

Total Amount of Bid: \$ _____

AWARD (To be completed by RurAL CAP)

Contract#: _____

Amount: \$ _____

Signature: _____

Name, Title: Tiel Smith, Chief Executive Officer

Date of Award: _____

APPENDIX H

ADDITIONAL PROVISIONS

CONTRACT TERM

The term of this contract is one year. RurAL CAP reserves the right to offer an extension of the term of the contract for up to two additional years on a year-by-year basis beyond the original termination date so long as it is in the best interests of RurAL CAP. The contractor reserves the right to refuse such an offer of extension.

The contract will be awarded on a fixed price basis. The basis of the award will be the unit prices presented in the bid document.

Any proposed increase or decrease in unit prices over the course of the contract term will be presented to RurAL CAP by the contractor. RurAL CAP reserves the right to re-negotiate unit prices with the contractor when it is in the best interest of RurAL CAP or, when it is justifiable based on information presented by the Contractor.

REFERENCES

All bidders to provide minimum of three references that have used the vendor's services within the past three years. Provide company name, contact person, phone Number. Preferably these references will be for construction projects in remote, rural villages.

OTHER PROJECTS

RurAL CAP anticipates additional projects other places that may be included under this contract so long as it is in the best interests of RurAL CAP.

ATTACHMENT I

BID EVALUATION

Bid will not be accepted if materials do not meet minimum Specification's contained in the bid package.

Each bid shall be evaluated using the worksheet attached. Vendors may be asked to provide further documentation in addition to that required in the specifications to substantiate bid information.

A minimum of three (3) people will evaluate each acceptable bid regarding rating categories #1 to# 4.

- Each person will evaluate each bid proposal independently.
- Each person will determine numerical rating for Supplier's capabilities and compliance with the bid packet requirements for each category. An average rating will be midrange, a poor rating will be at the low end and an excellent rating could earn the maximum points allowed.
- Each person may annotate reasons for each rating given.

Rating category #5 will be a fixed, calculated amount determined by dividing the lowest submitted bid by the Suppliers total bid, then multiplying by the Maximum points allowed.

All bid totals submitted will be checked for accuracy based on the unit price for each item and estimated quantities requested. If different from the submitted bid total, these adjusted amounts will be used.

BID EVALUATION WORKSHEET

Company Name: _____
Bid Type: _____
Rater: _____
Rating: _____

Overall rating will be the sum of points bases on the following criteria:

- 3. Has the bidder successfully provided the materials/ services for remote projects in the past:
(All bidders must submit a minimum of three rural Alaska references, including Company, Contact Person, and Phone Number as part of the bid packet)
Points (Maximum 20) _____
Notes: _____

- 4. Did Bidder provide required documentation showing materials/services meet quality standards/specifications as set forth in the bid package:
Points (Maximum 10) _____
Notes: _____

- 5. Did Bidder bid on all materials/services in accordance with bid specifications?
Points (Maximum 10) _____
Notes: _____

- 6. Did Bidder provide unit pricing for each material item with accurate extended and total costs and separate pricing for freight cost to F.O.B. designated?
Points (Maximum 10) _____
Notes: _____

- 7. Rating of total cost of bid (materials/services, including freight cost to F.O.B. designated):
Low Bid Total \$ _____ Bidder's Total \$ _____
Points (Maximum 50) _____
Overall Rating _____

ATTACHMENT II

SPECIFICATIONS FOR MATERIALS BID PACKAGE ARE AS FOLLOWS:

The successful bidder must be able to supply the bulk material order within a maximum time frame of thirty (30) days (including Saturdays, Sundays and Holidays) from date of purchase order receipt to delivery F.O.B Anchorage International Airport.

NOTE: Any product which is substituted as equivalent as or better than a product listed in these specifications must be identified by brand and model with supporting specifications.

Part #	Material:
1203/4	Beveled trim, baseboard to be wood product in light/medium oak color.
1265	To be one (1) bundle #1 cedar roofing shingles,
1400 - 1532	Lumber price to be per lineal foot unless specific length is noted, in which case a per piece price is requested.
1411-1414 1416-1417 1502 - 1532	All 1"x clear material shall be kiln-dried (KD) clear, straight or mixed grain fir or hemlock. Minimum length is eight (8) feet and maximum length is twelve (12) feet unless otherwise specified. All S/B lumber to be KD standard or better grade (S/B), hemlock/fir (HF) or spruce/pine/fir (SPF).
1672- 1674	T1-11 siding to be all wood and shiplap edge in 4' wide panels by length specified. The siding to be pre-primed with a slow dried primer that has a tannin stain blocker additive to prevent bleed-through. Prefer no-groove finish.
1680 - 1682	Siding cap is a fabricated galvanized Z-metal type 29-gauge flashing to be used to cap the top exterior edge when foam board and siding are used to cover existing exterior surfaces. Minimum lip edge to provide secure coverage to be two (2) inches top and bottom. NOTE: See attached drawing for example.
1738	Pressure treated All Weather Wood suitable for wood foundations, ground contact or below grade applications, standard or better with a .60 treatment.
1740 - 1785	Pressure treated wood suitable for above grade applications, standard or better with a .40 treatment.
1880	Paneling to be all wood manufacture. Plastic laminate not acceptable. Paneling to have light colored surface unless specified otherwise.
1920	Mechanically attached sweep with a 1" minimum nylon brush and minimum 1" PVC. To include attaching screws.
1922	Arctic rubber type, mechanically attached door shoe, to cap the bottom of a door. To include attaching screws.
1925	Weather-strip to be 100% silicon with 1" aluminum extrusion to seal a 3-0 x 6-8 door, including screws.

MATERIAL SPECIFICATIONS

(continued)

- 1926 Weatherstrip, Thermal Brush to be ¾" 40° angle aluminum flange with 1" brush material equivalent to Sealeze J140C1A1oBL17, to seal 3-0 x 6-8 door including screws.
- 1941 Mechanically adjustable threshold (capable of being shortened on either one or
1942 both sides to fit existing odd-size door jambs).
- 3035 - 3037 All staples must be for Arrow T-50 type staplers. (Box equals 1,250 staples)
- 3106 - Nails will be ordered by the box unless a specific weight is noted on the PO.
- 3363 - All drywall screws to be galvanized, zinc coated or equivalent to provide
3371 protection against weather and rusting.
- 3643 Tar material for roof patching, etc. which can be applied to either wet or dry surfaces.
- 3883 Acrylic latex caulk meeting ASTM C834-10 / White
3884 Acrylic latex caulk meeting ASTM C834-10 / Clear
- 3889 A single component, paintable, elastomeric sealant equivalent to Flexseal that adheres to most substrates in wet or dry conditions and can be applied at temperatures as low as -20 degrees F.
- 3883-3889 **NOTE:** All caulk to be supplied in plastic 10.3 ounce tubes.
- 3962 High temperature "caulk" to use for sealing stovepipe, etc. which will be in contact with high temperature surfaces to 2000°.
- 3981 A fibrous adhesive duct sealant tested to ASTM E-84 for flame spread and smoke density. It is manufactured by RCD Corp., 2310 Coolidge Ave., Orlando, FL 32804. (Phone 407 - 422-0089)
- 4150 Polyurethane filler foam and cleaner in container which screws to dispensing gun. Minimally
4152
4154 expanding foam, Class A or Class 1 per ASTM E84. Filler form to be supplied in approximately two (2) liter / 24 oz can, cleaner in 12 oz can.
- 4596 EPA-Certified air tight wood stove with outside combustion air kit and a heat circulating fan, similar to a True North Model TN19.
- 4600 - All 6", 7" and 8" chimney Metalbestos (M/B) or parts refer to "Selkirk
4826 Metalbestos" brand double-wall, insulated stove pipe and parts. **No substitutes will be acceptable.**
- 4970 - All single wall stove pipe and parts to be 24 gauge minimum, black unless
4997 otherwise specified.

MATERIAL SPECIFICATIONS

(continued)

- 5200 Blowfill insulation to be chopped fiberglass conforming to ASTM C687-07, similar to Knauf "Jet-Stream". Coverage to be equivalent to 73.3 square feet per bag for R-30 insulation.
- 5201 Aluminum flashing to keep blowfill insulation from contacting stove pipe.
To be supplied in 20" x 50-foot rolls
- 5214 Wire batt hanger, typically 12 gauge steel, used between floor joists to support batt
5215 insulation.
- 5217 - All fiberglass insulation shall be certified to comply with the CCR, Title 24, Part 5229 12,
5232 Chapters 12-13. Flexible (batts) insulation must conform to ASTM C665-06.
- 5357- Medium density extruded polystyrene with an R-5 per inch insulation value, .6
Perm rating maximum in 4' x 8' sheets. (DOW pink, Foamular 150, etc) Must
meet ASTM C578-95.
- 5360 - Poly foil faced board is polyisocyanurate foam board covered with foil both sides
5362 in 4' x 8' sheets, having an R-7 per inch insulation value. (RMax, Thermax, etc).
Must meet ASTM C1289-10 or FS (Federal Specifications) HH-I-1972/1 (1981).
- 5363- Expanded Polystyrene with an R4.5 per inch insulation value in 4' x 8' sheets. (R-Tech, etc.)
5365 Must meet ASTM 2430-05. Foil-faced one side, plastic face on other side.
- NOTE:** All foam board to be "packaged" with minimum of one piece of plywood on both the top and bottom of the bundles (max 48 inches high), preferably with plywood on all four sides, and wrapped in plastic protective layer. The plywood/siding packaging may be part of the bulk material order for the village.
- 5560 - Quantity listed as specified width by 100-foot roll unless otherwise stated. All
5565 vapor barrier to be supplied in 6 Mil clear unless otherwise specified. Meet ASTM
C1136-07. Permeance less than 1 when tested to ASTM E96.
- 5978 Air barrier / moisture plane for use between wall sheathing and siding. (Tyvek, TruTuff,
5979 etc.) Must meet ASTM E1167-05.
- 6502 Special eave trim flashing. See attached drawing for details.
- 6504 Ridge cap to include sufficient closure strip (1" x 1" foam) to seal edge joint.
- 6601 Roofing metal to be typical 26 gauge or better galvanized zincalune in three foot (3') width by
length required. Must meet ASTM D6294/D6294M-98 for corrosion resistance.

MATERIAL SPECIFICATIONS

(continued)

- 6700 Roofing membrane with a rubberized asphalt adhesive backed by a layer of high density cross laminated polyethylene. (Grace Ice & Water Shield, etc.). Must meet ASTM D5019-07A.
- 6881 - Gable vents shall be louvered with a corrosion-resistant bug screen with
6882 12" x 12" or 12" x 18" rough opening and a separate cover, unless otherwise specified.
NOTE: See attached drawing for cover specs.
- 9511 Exterior premium grade high percentage (minimum 45% solids) all-acrylic latex solid color stain with one coat sealing capability similar to Glidden / ICI- FLO14020 "Flood SWF".
- 9518 Latex type vapor barrier paint similar in characteristics to Glidden "Vapor Barrier Interior Primer Sealer 1060-1200". Must have perm rating of 1.0 or less. To be tinted to an "off-white" color
- 9522 Shall be premium quality interior acrylic latex semi-gloss tinted to an off-white color.
- 9730 Smoke detectors to be photoelectric type with a five (5) year battery. Ion type detectors are not acceptable.
- 9750 Floor tile to be typical commercial grade glue-down VCT type flooring in 12" x 12" pieces. Self stick type not acceptable.
- 9756-60 Typical medium oak or similar color cabinet in a basic contractor grade with wood doors.
- 9872 Countertop to be typical preformed laminate in a bone or off-white color.

MATERIAL SPECIFICATIONS
Drawings

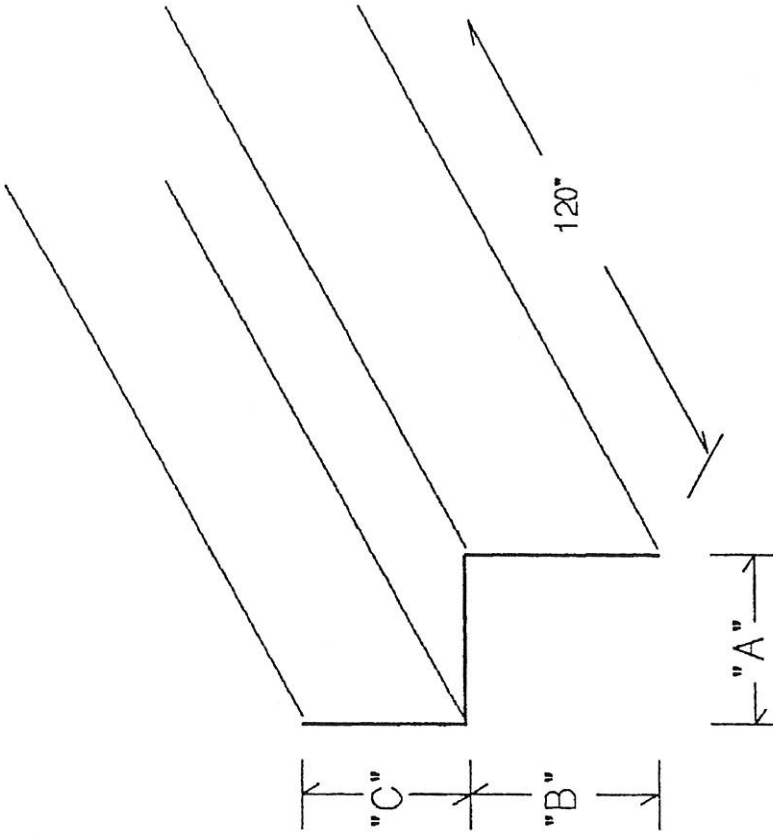

A	B	C
1"	2"	2"
1 1/2"	2"	2"
2"	2"	2"
2 1/2"	2"	2"

Siding CAP
"Z" Metal
29 ga. Galv. Steel
or Aluminum

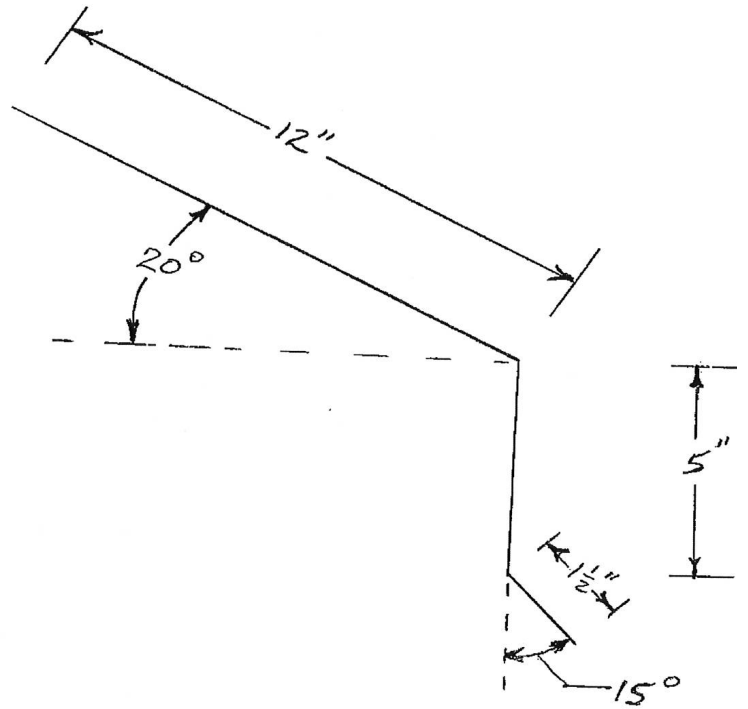
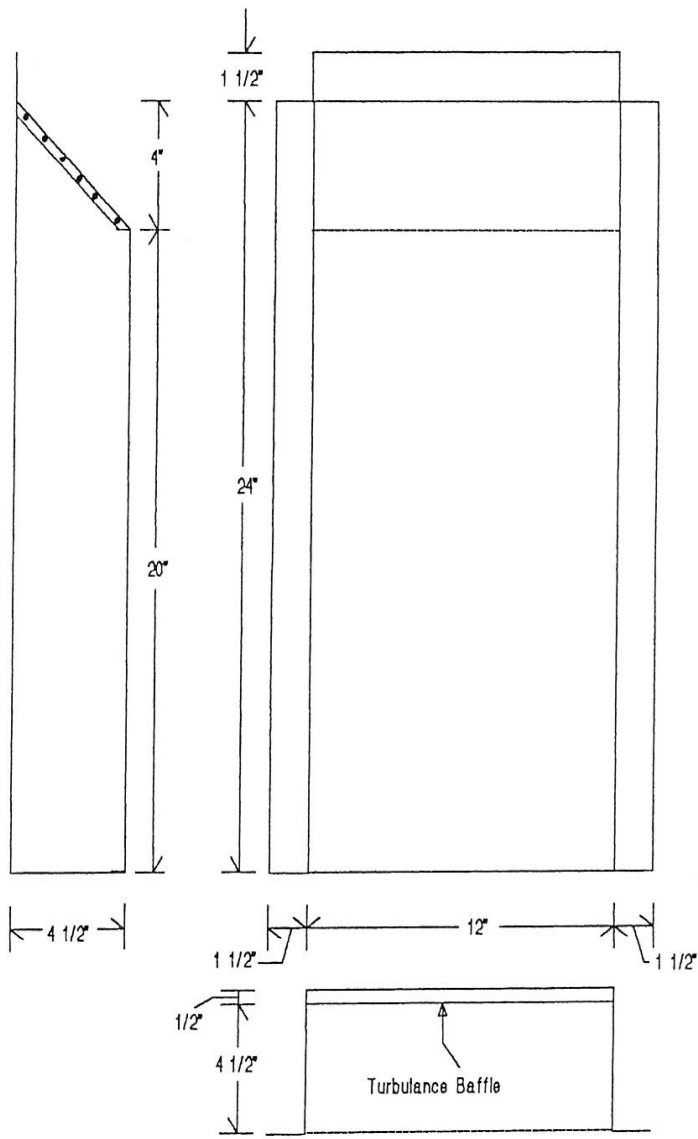

SPECIAL EAVE TRIM
 29 GA GALV. STEEL

Gable Vent Cover

SMALL
USING BRIFLES

22 GA GALV. SHEET METAL

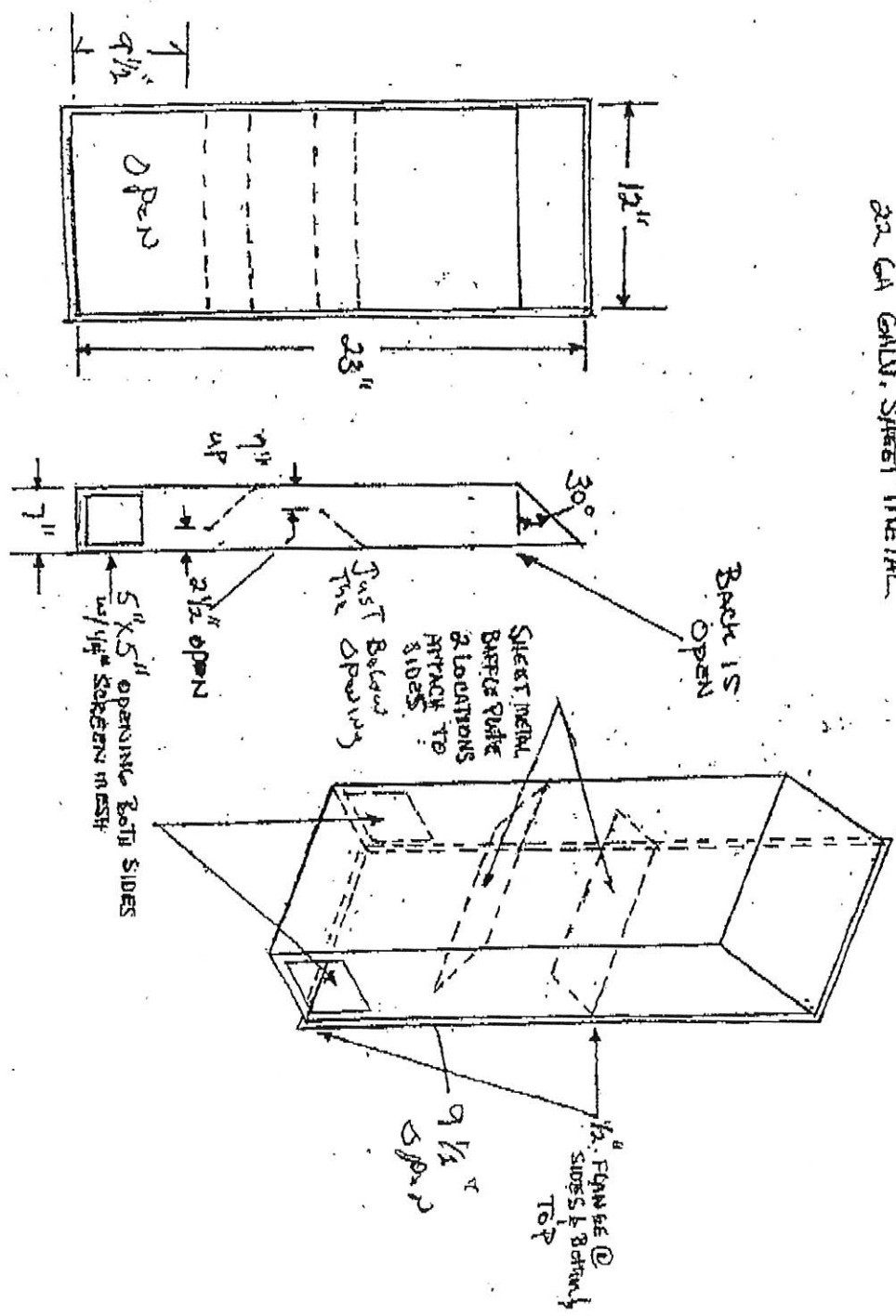

ATTACHMENT III—Materials Koyuk

Part #	Description	Type	Quantity
1203	BEVELED TRIM, 2 1/4" PREFINISHED AUTUMN OAK	Lin ft	550
1208	BATTEN, 1/4" X 1 5/16" X 8'	Each	353
1419	LUMBER 1 X 3 TIGHT KNOT CEDAR	Lin ft	325
1434	LUMBER 1 X 6 FINGER JOINT PINE (WHITE)	Each	20
1436	LUMBER 1 X 8 FINGER JOINT PINE (WHITE)	Lin ft	275
1444	LUMBER 1 X4 X 10' UTILITY BTR	Each	30
1521	LUMBER 2 X 2 X 8' S/B KD HF	Each	10
1525	LUMBER 2 X 4 X 12' S/B KD HF	Each	10
1526	LUMBER 2 X 6 X 8' S/B KD HF	Each	2
1752	PRESSURE TREATED 2 X 6 X 8 BRN 40%	Each	12
1772	PRESSURE TREATED 4 X 4 X 10 BRN 40%	Each	4
1854	PLYWOOD AC 1/2" X 4 X 8 EXT SANDED	Each	12
3780	JOINT COMPOUND GALLON	Each	2
3781	DRYWALL JOINT TAPE 2" X 75'	Roll	1
3883	CAULK, ACRYLIC LATEX CLEAR 10.3 OZ	Tube	48
4600	6" X 18" S-18 METALBESTOS PIPE	Each	2
4601	6" X 36" S-36 METALBESTOS PIPE	Each	5
4602	6" T-CT ROUND TOP METALBESTOS	Each	2
4605	6" T-SC STORM COLLAR METALBESTOS	Each	5
4607	6" T-AF6 M/B ROOF FLASHING (0 TO 6/12 PITCH)	Each	2
4611	6" T-FSP M/B FINISH SUPPORT PKG (MOUNTS ON CEILING)	Each	2
4614	6" T-DSAC M/B DRIPLESS SMOKE ADAPTER	Each	2
4981	STOVE PIPE BLACK SW 24 GA 6" X 2'	Each	15
5200	INSULATION "KNAUF JET-STREAM" BLOWFILL (29 LB. BAG)	Each	97
5357	INSULATION EXTRUDED POLYSTYRENE 2" X 4 X 8	Each	26
6985	RANGE HOOD WALL CAP W/ DAMPER, 3 1/4" X 10" #639BL	Each	4
6986	RANGE HOOD WALL Duct, 3 1/4" X 10" X 24"	Each	4
6987	RANGE HOOD CONVERTIBLE VENT 30 IN WHITE 403011	Each	5
6994	RANGE HOOD WALL CAP/DAMPER 6" BLACK 843BL	Each	2
9720	FIRE EXTINGUISHER--5 POUND A,B,C	Each	5
Materail Cost			
Crating, Packaging and Barging Cost			
Total Cost			